

Melt Pressure Transmitter Data Sheet

Industrial Pressure Transmitter

Model: CMPT124B-129

Introduction

◆ CMPT124B-129/129T Series intelligent Melt pressure transmitter (Flexible stem) is a high-accuracy and high-stability pressure instrument designed by digital circuit compensation technology with LCD display and explosion-proof housing, it's specially used in the occasion of 4-20mA (2-wire) with hart protocol optional. It is used in the equipment of chemical fiber, polyester, and other pressure measuring and controlling of melt fluid medium.

Application

- ◆ Chemical fiber equipment
- ◆ Plastic extruder equipment
- ◆ Polyester equipment
- ◆ Other pressure measurement and Control

Features:

- ◆ High-standard quality
- ◆ Explosion-proof housing
- ◆ With LED Local display
- ◆ Simple installation
- ◆ Internal 80% calibration
- ◆ Excellent stability and repeatable

RoHS

CE



Dimensions(mm):

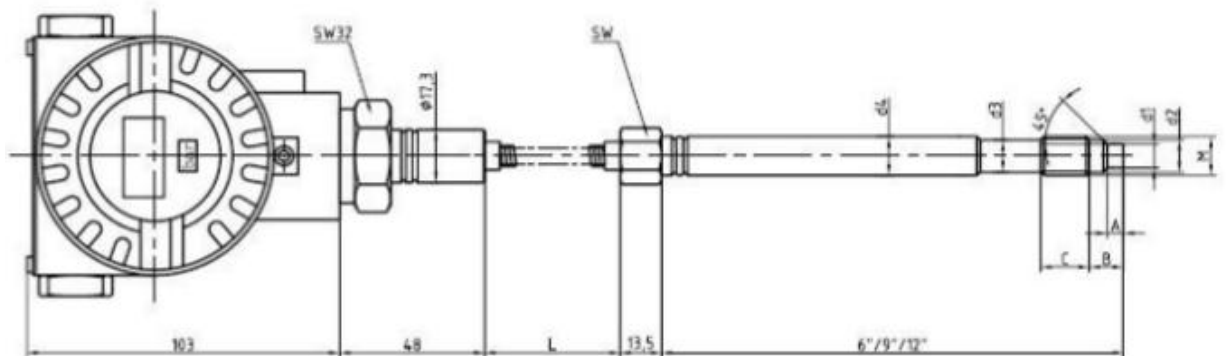

Technical Characteristics

Model	CMPT124B-129
Range	0....1MPa to 0....150MPa (0...150psi to 0...20000psi)
Output	4 ~ 20mA; HART

Melt Pressure Transmitter Data Sheet

Accuracy	$\pm 0.25\%FS$; $\pm 0.5\%FS$
Input voltage	24 (12~36) VDC
Repeatability	$\pm 0.2\%$
Construction:	Wheatstone bridge
Bridge resistance	350 ohms $\pm 10\%$
Overload pressure	1.5 \times FSO
Internal calibration	80%FSO $\pm 1\%$
Insulation Resistance	1000Megohms @50Vdc
Max. Diaphragm Temp	0~400°C
Electric connector	Wiring terminal
Process connector	1/2"-20UNF, M14 \times 1.5, M18 \times 1.5 (Option)

Mounting hole

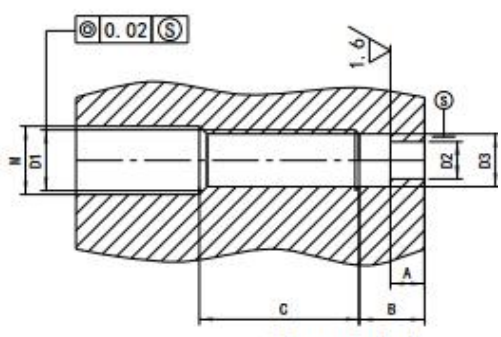
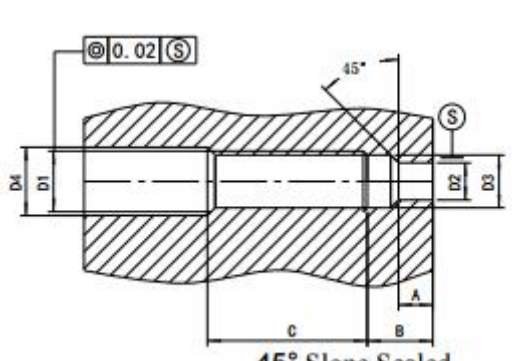
 <p style="text-align: center;">Planar Sealed</p>	D1	M22*1.5	M28*1.5	G3/4"	PT3/8"
	D2	$\Phi 16.1$	$\Phi 18.3$	$\Phi 18.3$	$\Phi 10.3$
	D3	$\Phi 20.1$	$\Phi 26.1$	$\Phi 24.2$	$\Phi 14.9$
	M	$\Phi 23$	$\Phi 30$	$\Phi 21$	$\Phi 11$
	A	11	12	12	14
	B	12	15	15	19
	C	40	35	35	40
 <p style="text-align: center;">45° Slope Sealed</p>	D1	M12*1.5	M14*1.5	1/2-20 UNF	M18*1.5
	D2	$\Phi 8$	$\Phi 8$	$\Phi 8$	$\Phi 10.1$
	D3	$\Phi 10.8$	$\Phi 12.5$	$\Phi 11.5$	$\Phi 16.1$
	D4	$\Phi 12.5$	$\Phi 14.5$	$\Phi 13.1$	$\Phi 20$
	A	6	6	6	6.5
	B	9	9.5	9.5	10

Melt Pressure Transmitter

Data Sheet

Attention for installation

◆ **Installation** Do not remove protective cap until ready to install. Prior to initial installation, verify correct machining of mounting hole. Install with aluminum gasket. The electronics housing should be secured, with the enclosed mounting bracket.

◆ **Remove** Make sure that there is no remained metal or plastic; remove all of the transducers from the equipment before you clean the extruder. You can remove the transducer only when the polymer is molten. And clean the diaphragm of the transducer with soft cloth as soon as you remove it. At the same time, you can use ZHYQ's cleaning tool kit to clean the remained material in the mounting hole in order to install easily next time.

◆ **Start-up** Bring system to operating temperature, and with no pressure, follow recommended procedures with instrumentation for zero and span adjustment. Make sure that there is sufficient "soak time" to assure that any material at the tip of the transducer is molten before process is started.

◆ **Electrical house** The tip of the transducer can endure high temperature, but the shell (electrical house) only endure temperature lower than 80°C, so it should place in the room temperature. It can benefit for the accuracy and natural life of the transducer if you keep the shell from the high temperature.

◆ **Overload effect** During the course of pressure measuring and controlling, it is better to make sure the transducer within the rated pressure, too long time overload the pressure will affect the accuracy and natural life of transducer, although the transducer own determinate overload ability.

◆ **Wiring** Use shielded cable, attach cable shield to ground at one end only. In order to prevent the jamming.

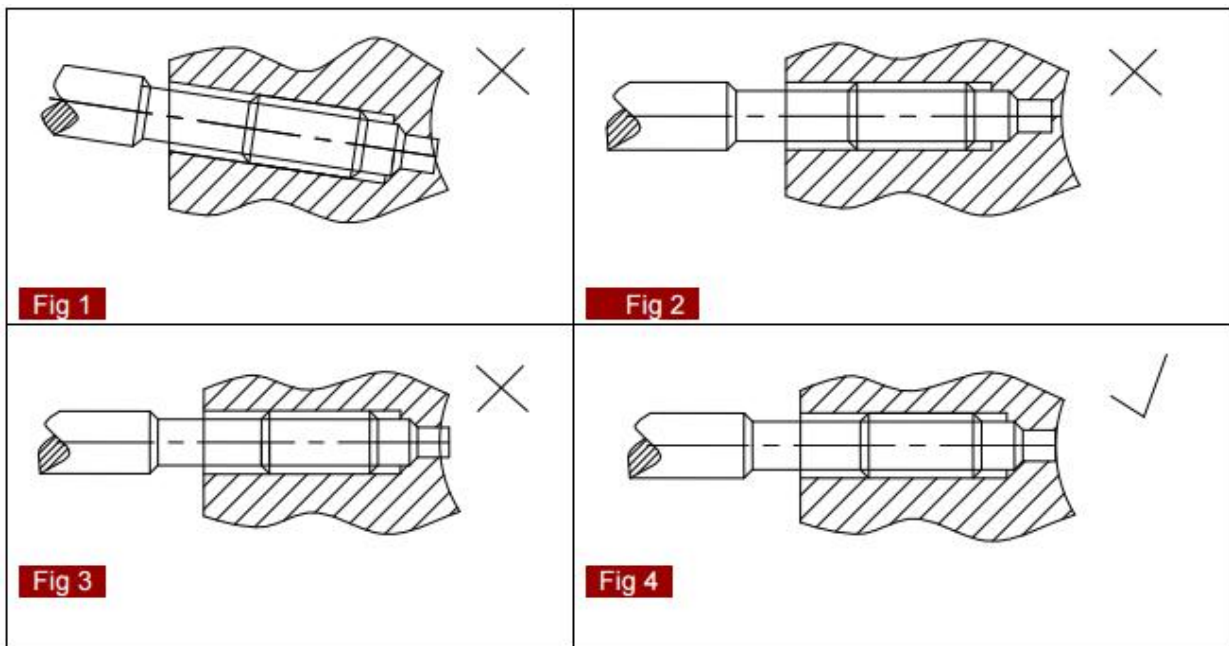





Three buttons instruction for mainboard of intelligent transmitter



"M"- Function key, "S"- Span adjust key, "Z"- Zero adjust key.

Program Instruction for the mainboard.

1, Unlock		Press <Z> and <S> and hold on for 5s to open the lock. (LCD screen display: OPEN)
2, PV value reset		At no-load, and unlock condition, press <Z> and <S> and hold on for 2s, the PV value will be 0. (LCD screen display: PV=0)
3, 4mA active migration		Zero adjust: Add "0" pressure to the transmitter, press <Z> for 2s, the transmitter gives output 4.000mA. (LCD screen display: LSET)
4, 20mA active migration		Span adjust: Add "Span" pressure to the transmitter, press <S> for 2s, the transmitter gives output 20.000mA. (LCD screen display: HSET)
5, Data recovery		Press <Z>, and connector the power, hold on press <Z> for 5s, if LCD screen display OK, the data recovery to the original state, then release the <Z>. If LCD screen display FAIL, it means there is no backup data, it could not recovery to the original state.

Remarks: The transmitter will auto lock when there is no press to any button. You need to open the lock again.

Melt Pressure Transmitter Data Sheet

Measuring mode

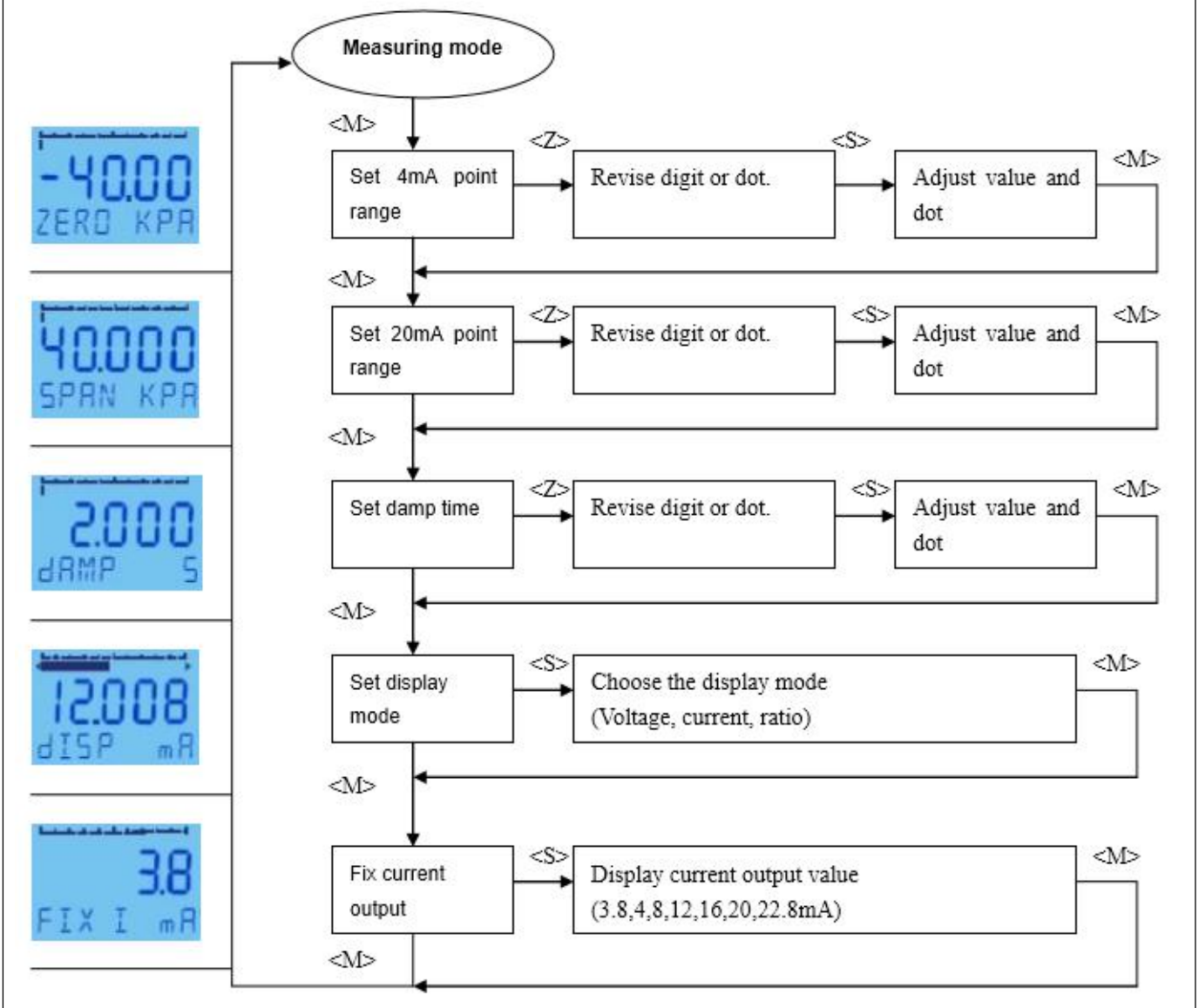

Ordering Guide

Model	Range (bar)	Output	Screw Thread	Electric connection	Accuracy	Diameter (mm)	Other requirement
CMPT124B-129	*	*	*	*	*	*	---

Example: CMPT124B-129-500Bar-4/20mA-1/2-20UNF-6PIN